



FLAVORFUSION™

POST-MIX ICE DRINK DISPENSER



SHOWN IN OPTIONAL
FUSION GREEN

FEATURES:

- 16 brands in a 30" footprint increases brand density
- Dedicated bonus flavor nozzles can add up to 8 additional flavors for creating a unique drink experience
- Maximum adjustability: Flavor shot dispense times and flow rates are easy to adjust
- No flavor carry-over for brand or flavor shot
- Cold carbonation provides consistent drink quality
- Total flexibility for carbonated / non-carbonated drinks for each brand button
- Easy motor removal (does not require removal of ice from hopper or removal of top mounted ice maker)
- Unit available in Midnight Black, Fusion Green, Orange Dream and Gun Metal Gray
- Increased drip tray capacity

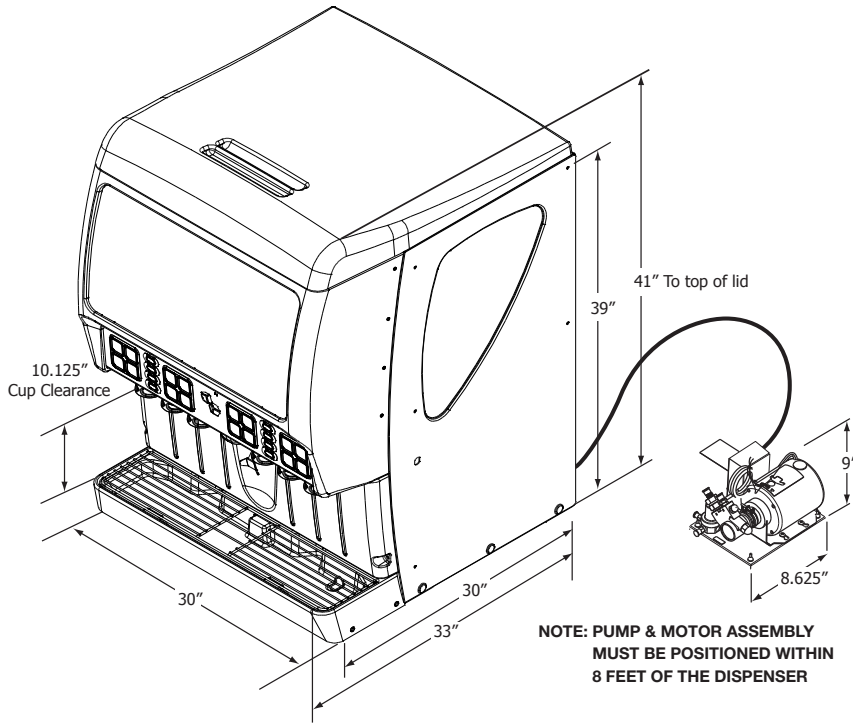

**NOTE: PUMP & MOTOR ASSEMBLY
MUST BE POSITIONED WITHIN
8 FEET OF THE DISPENSER**



**MIDNIGHT BLACK
STANDARD**



**GUN METAL GRAY
OPTIONAL**



**ORANGE DREAM
OPTIONAL**



PART NUMBER	DESCRIPTION
621057605	FlavorFusion™ - Fusion Green
621057607	FlavorFusion™ - Gun Metal Gray
621057606	FlavorFusion™ - Orange Dream
621057601	FlavorFusion™ - Midnight Black
629087406	Leg Kit contains four 4" (102 mm) legs

Order optional leg kit separately.

TECHNICAL SPECIFICATIONS:

DIMENSIONS 41"H x 30"W x 30"D
GRAPHIC SIZE (template available)
COUNTER WEIGHT 320 lb (plus ice weight)
SHIPPING WEIGHT 365 lb
CAPACITY 255 lb ice bin capacity
for cubed & chunklet
(compressed) ice
AMP DRAW 120 V / 60 Hz / 9.3 Amps
ELECTRICAL RATING 115 V +/- 10% (only
requires single outlet)
WATER SUPPLY PRESSURE 50-60 psi at pump
CO₂ 75 psi at carbonator tank

16 BRAND SYRUPS:
(14 CHILLED / 2 AMBIENT) 60 psi/min
8 FLAVOR SHOT SYRUPS:
(AMBIENT) 20-25 psi/max
VALVE OPTIONS 16 push button brands
2-4 oz/sec valves
CUP CLEARANCE 10.125"
STANDARD FEATURES Timed agitation,
beverage keyswitch

AGENCY LISTINGS
 
City of Los Angeles

